

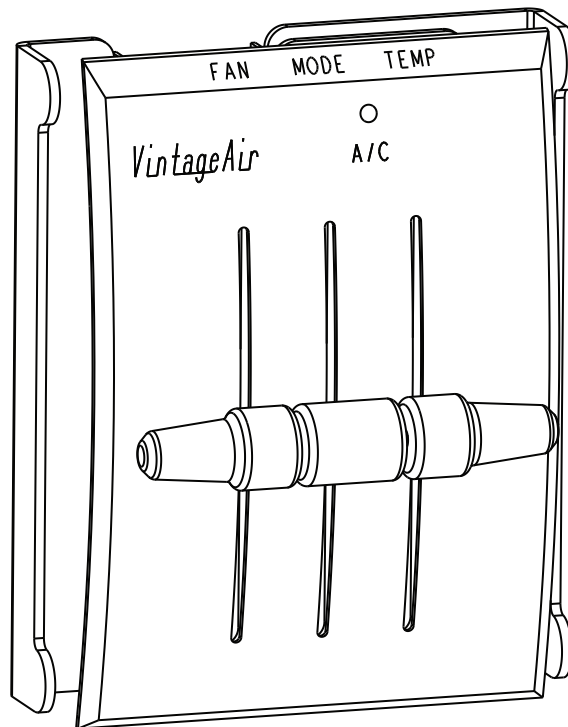

1964 1/2-66 Ford Mustang

Control Panel Kit (473101)



18865 Goll St. San Antonio, TX 78266
Phone: 800-862-6658
Sales: sales@vintageair.com
Tech Support: tech@vintageair.com
www.vintageair.com



www.vintageair.com

Table of Contents

Cover..... 1

Table of Contents..... 2

Packing List/Parts Disclaimer..... 3

Control Panel Installation..... 4

Control Panel Calibration Procedure..... 5

Control Panel Calibration Procedure (Cont.)..... 6

Gen IV Wiring Diagram..... 7

Gen 5 Wiring Diagram..... 8

Gen IV Wiring Connection Instructions..... 9

Gen 5 Wiring Instructions..... 10

Operation of Controls..... 11

Packing List..... 12

Important Notice—Please Read

This control panel is designed to only work with either a Gen IV evaporator unit equipped with a 246204-PUA ECU, or a Gen 5 evaporator unit equipped with a 246404 ECU. Please confirm that your unit has the proper ECU prior to installing the control panel as shown below. A replacement ECU can be purchased from Vintage Air if needed.





www.vintageair.com

Packing List: Control Panel Kit (473101)

No.	Qty.	Part No.	Description
1.	1	495010	Control Panel Assembly
2.	1	232007-VUR	Control Harness, Gen IV/Gen 5 Universal
3.	1	231520	Ground Wire

**** Before beginning installation, open all packages and check contents of shipment. Please report any shortages directly to Vintage Air within 15 days. After 15 days, Vintage Air will not be responsible for missing or damaged items.**

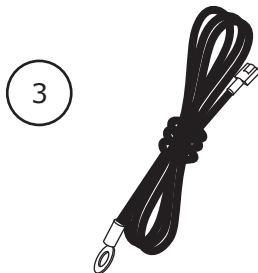
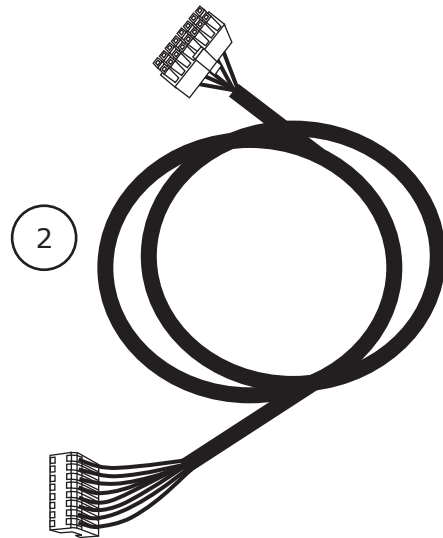
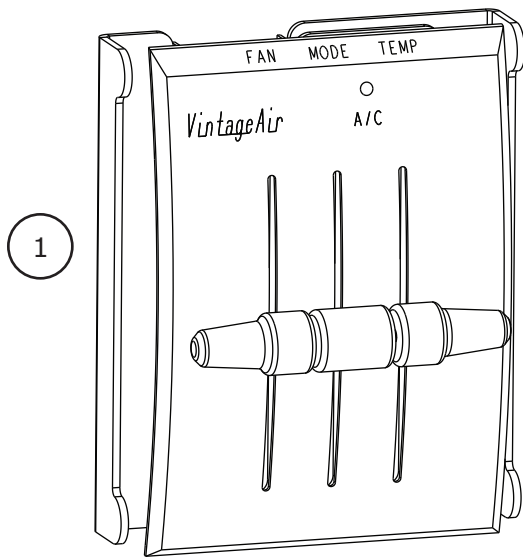



www.vintageair.com

Control Panel Installation

1. Insert the control harness through the dash opening.
2. Plug the control harness into the control panel assembly and the ECU on evaporator as shown in Figure 2, below, and on Page 7 or 8. **NOTE: Difficulty inserting harness connector into control denotes improper connector orientation. Do not force.**
3. Calibrate the control panel as shown on Page 5 and 6.
4. Confirm the control panel functionality as shown on Page 11.
5. Install the control panel into the dash by placing the control panel bracket behind the dash and securing it to the control panel assembly using a 10-24 nylon locknut (See Figure 1, below).

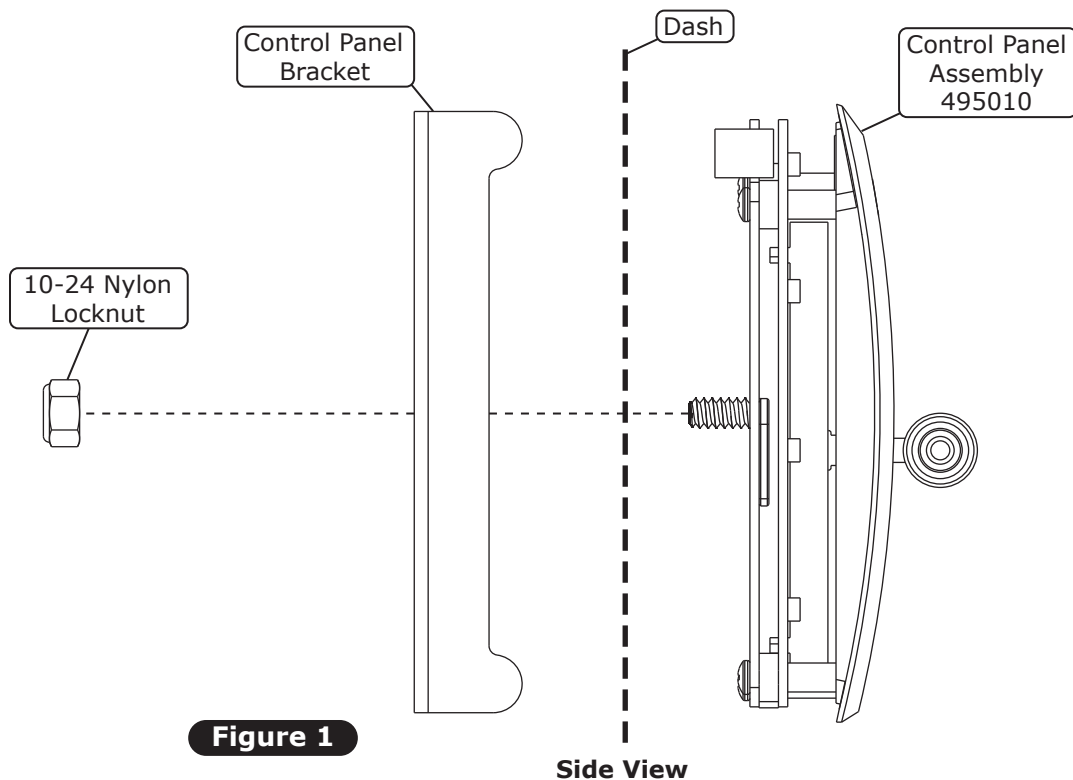

Figure 1

NOTE: When using a Vintage Air supplied control panel, connect the TAN 20 AWG wire from the Gen IV evaporator wiring harness (232010) or the Gen 5 evaporator wiring harness (231505) to the factory dash lights to enable panel backlighting.

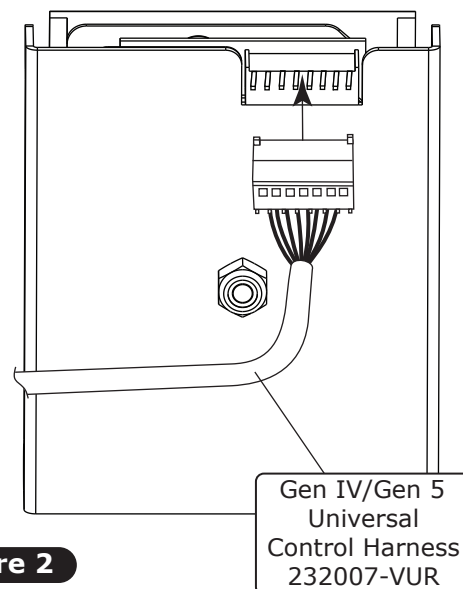
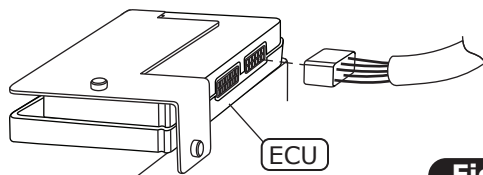

Figure 2



www.vintageair.com

Control Panel Calibration Procedure

On Vintage Air Gen IV and Gen 5 systems using cable converters or replacement electronic controls, it is necessary to calibrate the system to your specific control panel. This procedure ensures that the travel of your control panel levers or knobs is translated into precise control of the blower speed, temperature blend and mode door position. Please carefully read and understand these procedures before beginning. The procedure may be repeated as many times as necessary to get it right.

Gen IV Systems:

In preparation for calibration, you will need to attach the supplied white ground jumper wire (PN 231520) to a suitable chassis ground. This jumper wire must be easily connected to the gray programming wire located in the main Gen IV wiring harness next to the compressor relay. During the calibration procedure, you will connect the white jumper to the gray program wire, which will "teach" the Gen IV ECU the upper limits of the control levers or knobs. The blower will momentarily change speeds, signaling that the upper limits have been "learned". You will move the levers or knobs to opposite extreme positions of their travel and then disconnect the white jumper. The blower will pulse on/off, signaling that the lower limits have been learned and that the calibration procedure is complete.

Gen 5 Systems:

In preparation for calibration, you will need to attach the supplied white ground jumper wire (PN 231520) to a suitable chassis ground. This jumper wire must be easily connected to the gray programming wire located in the main Gen 5 wiring harness, see the Gen 5 wiring diagram and instructions for more information. During the calibration procedure, you will connect the white jumper to the gray program wire, and ground, which will then put the ECU into calibration mode. When the ECU is in calibration mode, the blower will default to medium speed and the ECU will flash a solid red light. Once in calibration mode you will cycle the controls as indicated in the calibration procedure on the next page. When complete, the jumper and program wire will be disconnected. The blower will turn off indicating calibration is complete.



www.vintageair.com

Control Panel Calibration Procedure (Cont.)

1. Turn on the ignition switch (Do not start the engine).

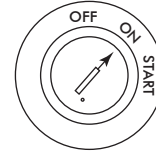

2. Move the control levers/knobs to the positions shown.

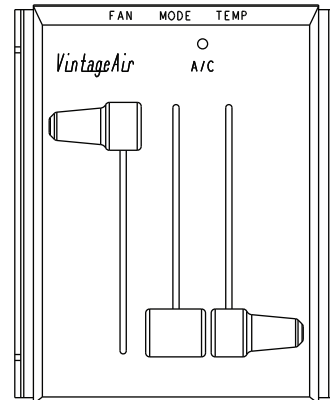

3. Connect the white jumper wire to the gray program wire. Wait approximately 5 seconds for the blower speed to change if using a Gen IV system, if using a Gen 5 system wait for the blower to default to medium speed.



4. Move the control levers/knobs to the positions shown.

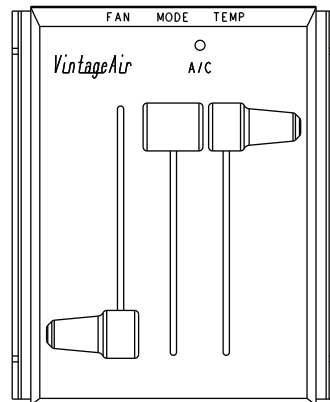

5. Disconnect the white jumper wire from the gray program wire. The blower speed will change if using a Gen IV system, and will shut off if using a Gen 5 system, indicating completion of the calibration procedure.

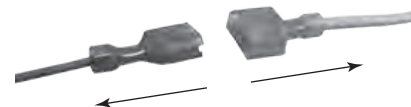

6. Confirm proper operation of controls. Repeat procedure if necessary. When finished, tape over program wire connector with electrical tape to prevent accidental contact with chassis ground.



www.vintageair.com

Gen IV Wiring Diagram

232007-VUR

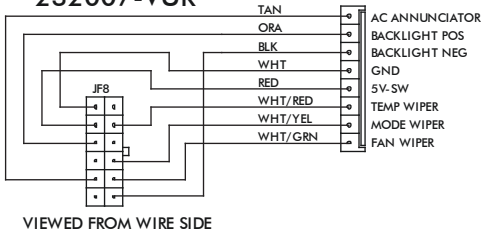

232002-VUA

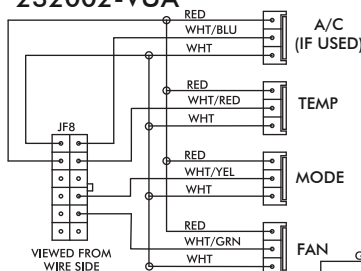

PROGRAM

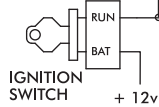
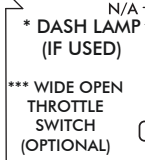

** CIRCUIT BREAKER 30 AMP

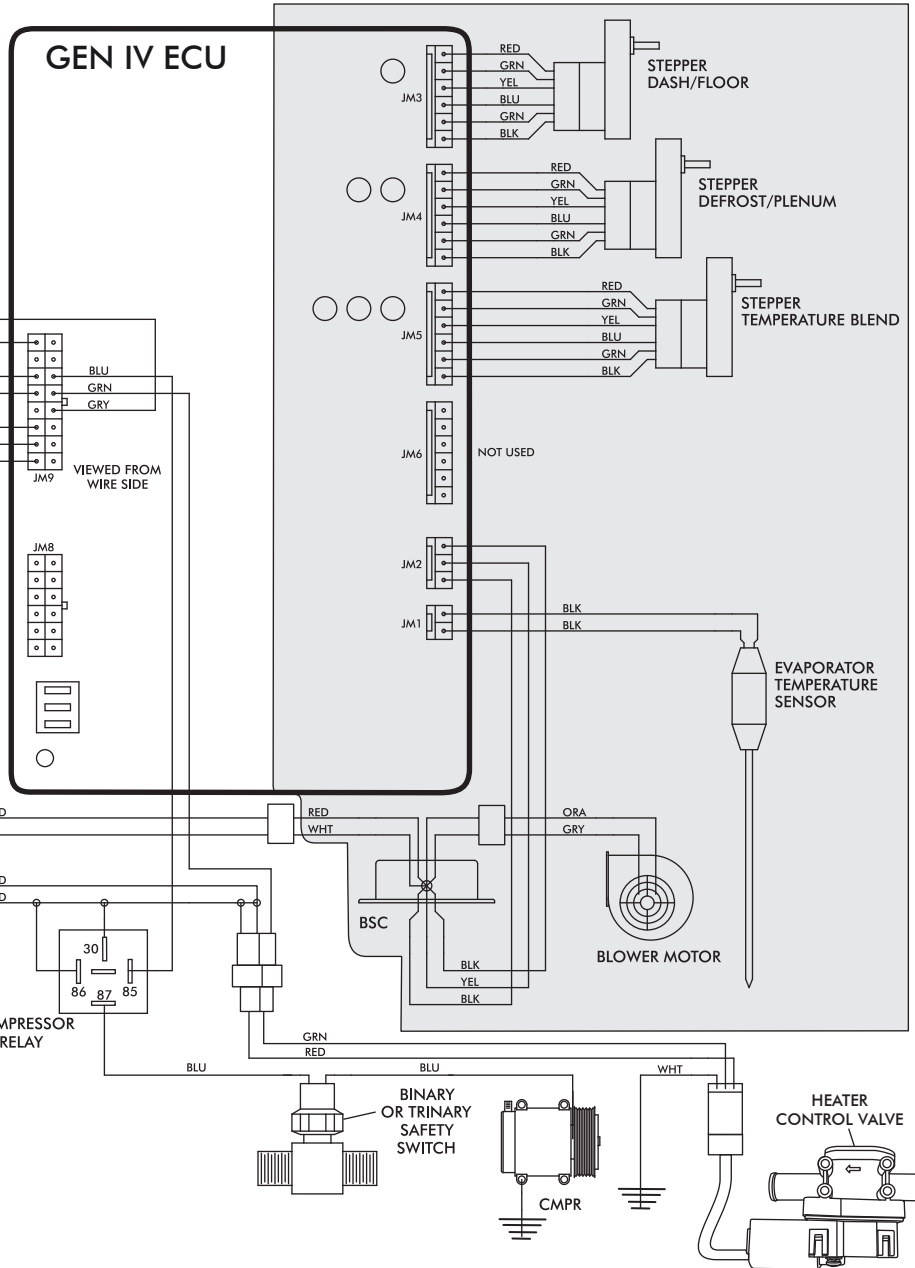

NOTE: = CHASSIS GROUND

* Dash lamp is used only with type 232007-VUR harness.

** Warning: Always mount circuit breaker as close to the battery as possible. (NOTE: Wire between battery and circuit breaker is unprotected and should be carefully routed to avoid a short circuit).

*** Wide open throttle switch contacts close only at full throttle, which disables A/C compressor.



www.vintageair.com

Gen 5 Wiring Diagram

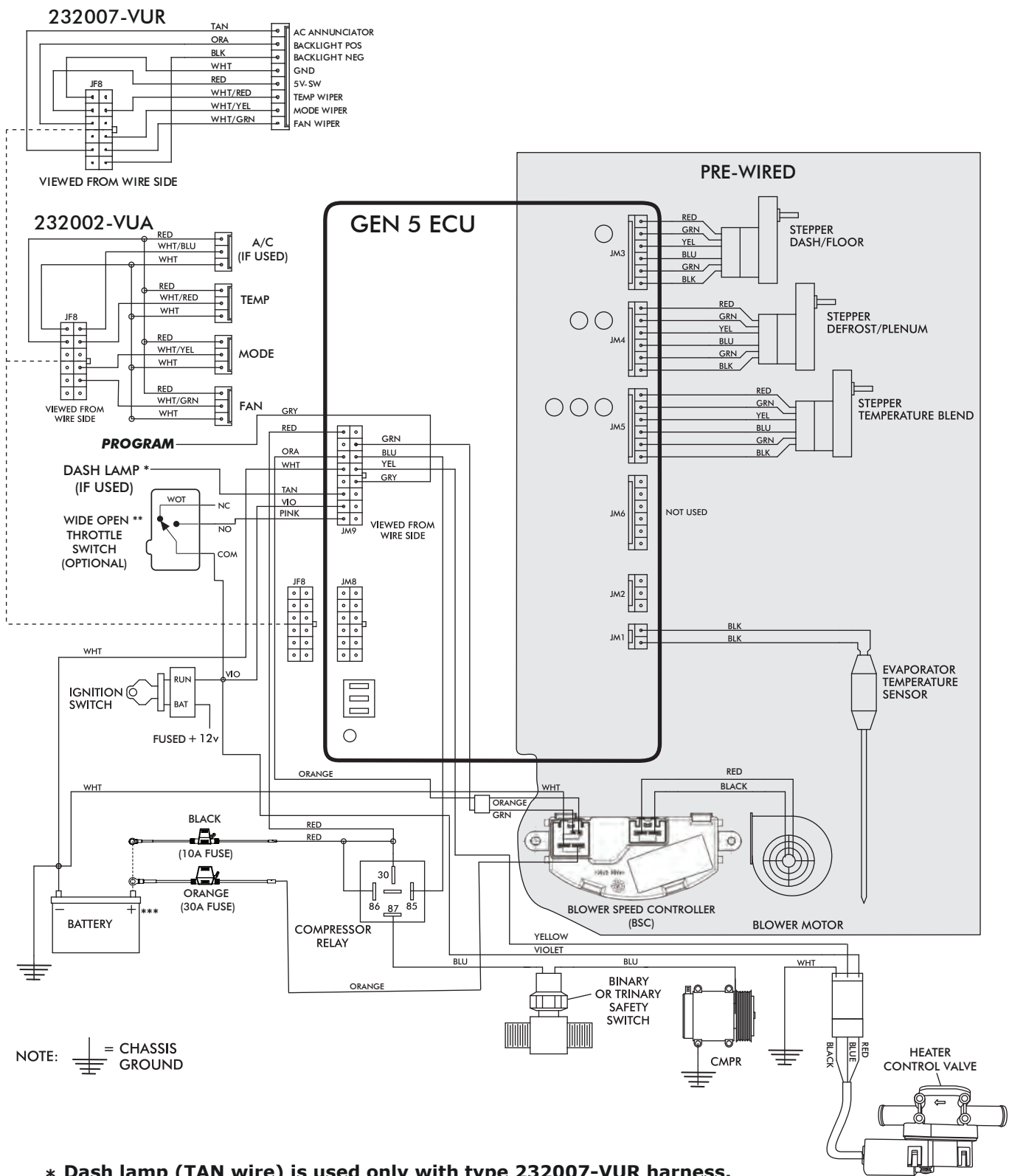

NOTE: = CHASSIS GROUND

- * Dash lamp (TAN wire) is used only with type 232007-VUR harness.
- ** Wide open throttle switch contacts close only at full throttle, which disables A/C compressor.
- *** Install fuse assemblies at or as near to the battery as possible.



www.vintageair.com

WIRING HARNESS

Gen IV Wiring Connection Instruction

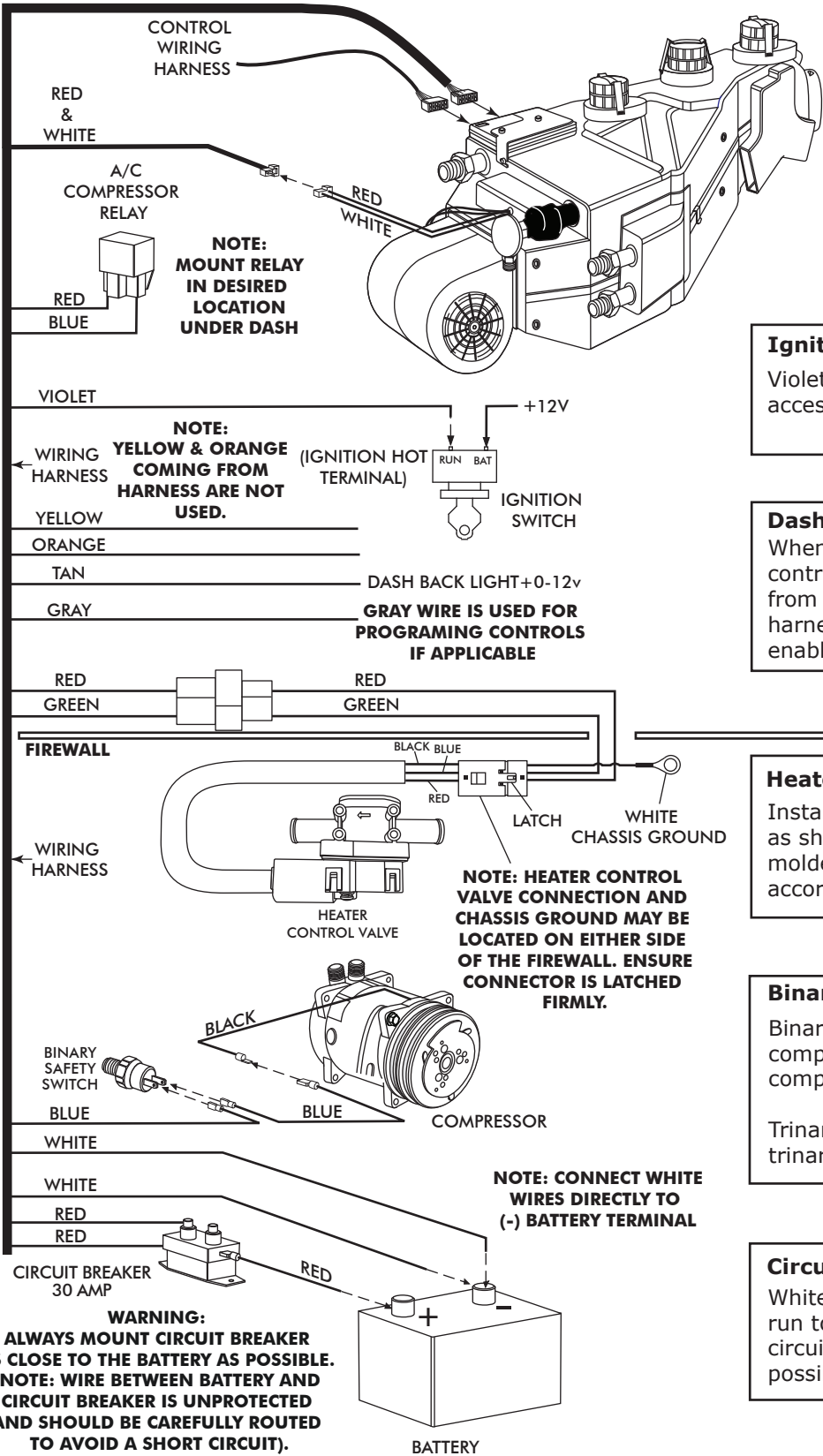

WARNING:
ALWAYS MOUNT CIRCUIT BREAKER AS CLOSE TO THE BATTERY AS POSSIBLE. (NOTE: WIRE BETWEEN BATTERY AND CIRCUIT BREAKER IS UNPROTECTED AND SHOULD BE CAREFULLY ROUTED TO AVOID A SHORT CIRCUIT).

Ignition Switch:

Violet 12V ignition switch source (key on accessory) position must be switched.

Dash Light:

When using a Vintage Air-supplied control panel, connect the tan wire from the Gen IV evaporator wiring harness to the factory dash lights to enable panel backlighting.

Heater Control Valve:

Install with servo motor facing down, as shown. Note flow direction arrow molded into valve body and install accordingly.

Binary/Trinary & Compressor:

Binary: Connect as shown (typical compressor wiring). Be sure compressor body is grounded.

Trinary Switch: Connect according to trinary switch wiring diagram.

Circuit Breaker/Battery:

White **must** run to (-) battery. Red may run to (+) battery or starter. Mount circuit breaker as close to battery as possible.



www.vintageair.com

Gen 5 Wiring Instructions

WIRING HARNESS (231505) ↓

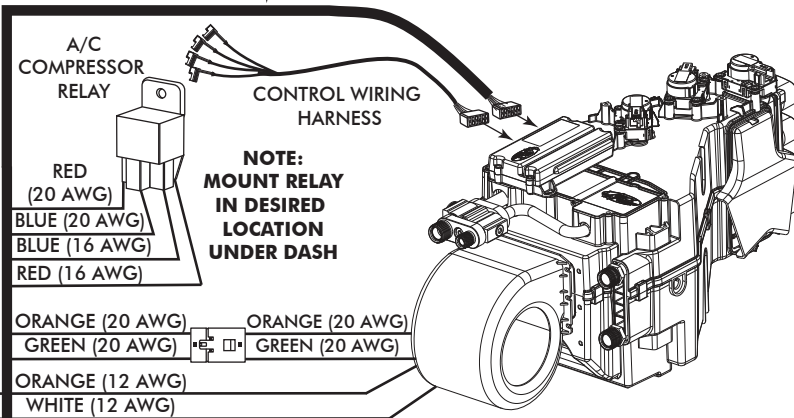

Ignition Switch:
Using provided butt splice (PN 226004), connect the 20 AWG violet wire to a 5A fused and switched 12V source such as Key On.

Wide Open Throttle Switch (Optional):
If a wide open throttle switch is required, connect the 20 AWG pink wire to a normally open switch that, when closed, connects a fused and switched 12V source to the pink wire. See Gen 5 wiring diagram for an example.

Dash Light (Optional):
If using a Vintage Air control panel with back light, connect the 20 AWG tan wire to the vehicle's dash back light 0-12V using provided butt splice (PN 226004).

WIRING HARNESS (232020)

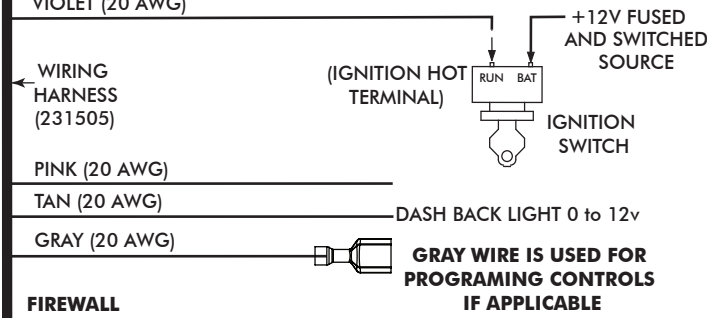

Heater Control Valve:
Connect the Violet/Yellow/White twisted branch with 3 position connector into the heater control valve connector. Ensure that the mating latch is fully seated.

Binary/Trinary & Compressor:
Binary Switch: Terminate provided insulated female terminal (PN 23172-VUW) to the blue 16 AWG wire. Connect as shown.
Trinary Switch: Connect according to trinary switch wiring diagram.

WIRING HARNESS (232020)

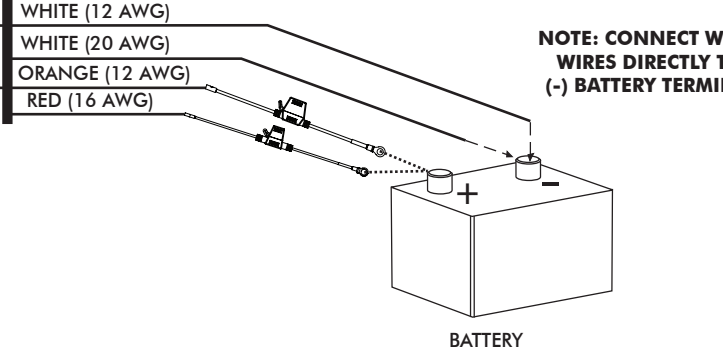
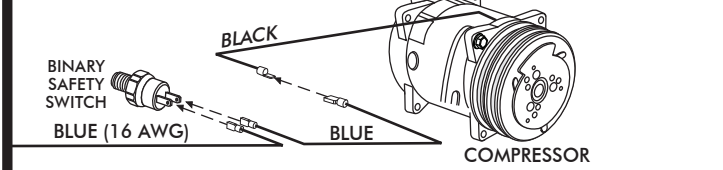
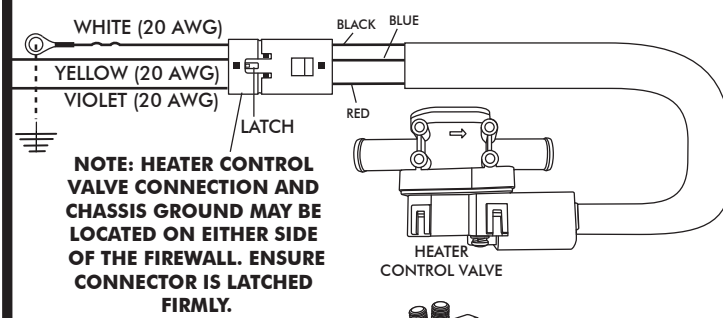

Battery Connections:
ECU Ground: Terminate provided ring terminal (PN 226110) to 20 AWG white wire from the 231505 wire assembly and install at battery.
ECU PWR: Terminate provided fuse assembly with black leads (PN 233012) to the 20 AWG red wire from the 231505 wire assembly. Install provided 10A Red Mini Fuse (PN 226118). Install at battery.
Blower Speed Controller (BSC) Ground: Terminate provided ring terminal (PN 226111) to 12 AWG white wire from the 232020 wire assembly and install at battery.
Blower Speed Controller (BSC) PWR: Terminate provided fuse assembly with orange leads (PN 233008) to the 12 AWG orange wire from the 232020 wire assembly. Install provided 30A Green ATO/ATC Fuse (PN 226125). Install at battery.



www.vintageair.com

Operation of Controls

On Gen IV and Gen 5 systems with three lever/knob controls, the temperature control toggles between heat and A/C operations. To activate A/C, move the temperature lever/knob all the way to cold and then back it off to the desired vent temperature. For heat operation, move the temperature lever/knob all the way to hot and then adjust to the desired vent temperature. The blower will momentarily change speed, each time you toggle in and out of heat and A/C operations, to indicate the change. **NOTE: For proper control panel function, refer to Pages 5 and 6 for calibration procedure.**

Blower Speed

This lever/knob controls blower speed, from OFF to HI.

Mode Control

This lever/knob controls the mode positions, from DASH to FLOOR to DEFROST, with a blend in between.

Temperature Control

This lever/knob controls the temperature, from HOT to COLD.

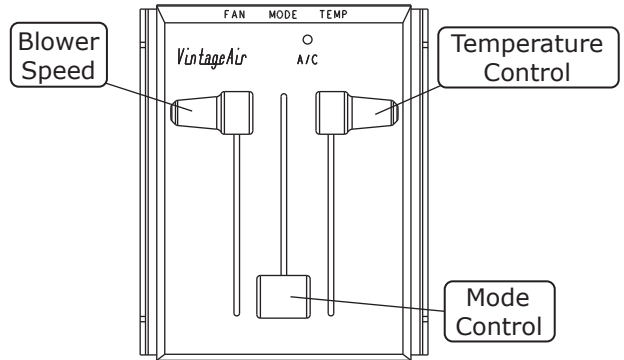

A/C Operation

Blower Speed

Adjust to desired speed.

Mode Control

Adjust to desired mode position (DASH position recommended).

Temperature Control

For A/C operation, adjust to coldest position to engage compressor (Adjust between HOT and COLD to reach desired temperature).

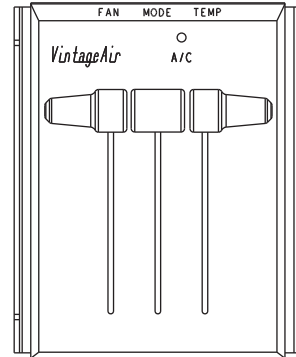

Heat Operation

Blower Speed

Adjust to desired speed.

Mode Control

Adjust to desired mode position (FLOOR position recommended).

Temperature Control

For maximum heating, adjust to hottest position (Adjust between HOT and COLD to reach desired temperature).

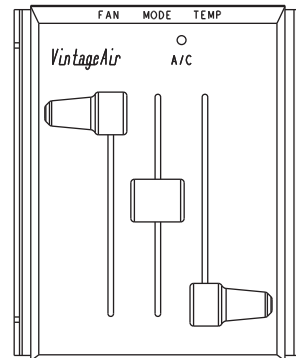

Defrost/De-fog Operation

Blower Speed

Adjust to desired speed.

Temperature Control

Adjust to desired temperature.

Mode Control

Adjust to DEFROST position for maximum defrost, or between FLOOR and DEFROST positions for a bi-level blend (Compressor is automatically engaged).

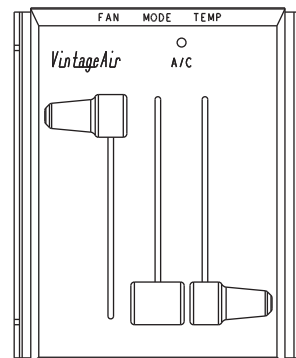



www.vintageair.com

Packing List: Control Panel Kit (473101)

No.	Qty.	Part No.	Description
1.	1	495010	Control Panel Assembly
2.	1	232007-VUR	Control Harness, Gen IV/Gen 5 Universal
3.	1	231520	Ground Wire

Checked By: _____
 Packed By: _____
 Date: _____

1

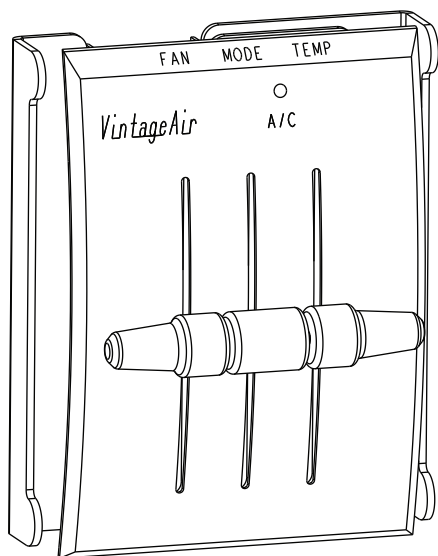

2

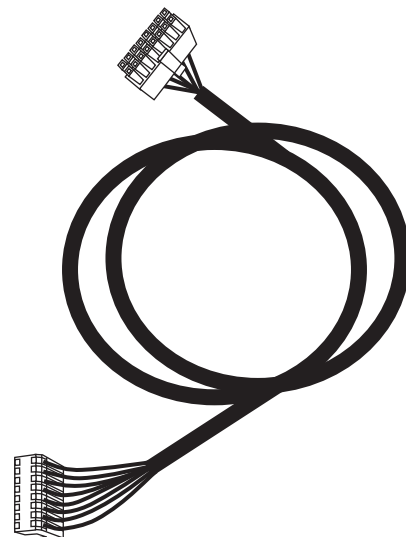

3



**NOTE: Images may not depict actual parts and quantities.
Refer to packing list for actual parts and quantities.**